

# Led Linea 5070

## Technical Data Sheet



Features \_\_\_\_\_

- Edison LED's
- Fulham Driver
- 3000K / 4000K / 6500K or TW 3000K to 6500K
- Ra>80



Options \_\_\_\_\_

- Through wiring
- Dimmable options



Accessories \_\_\_\_\_



Suspension Kit

Dimension \_\_\_\_\_  
in mm

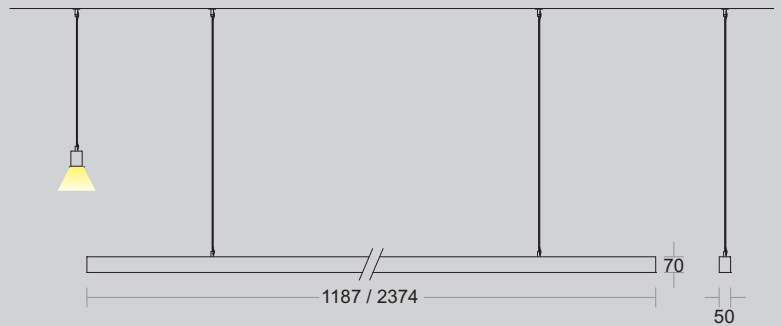

Housing Colour \_\_\_\_\_

- High-quality aluminium with powder coated finish in RAL9005 Black fine texture |
- RAL9016 White fine texture |
- RAL9006 Grey fine texture

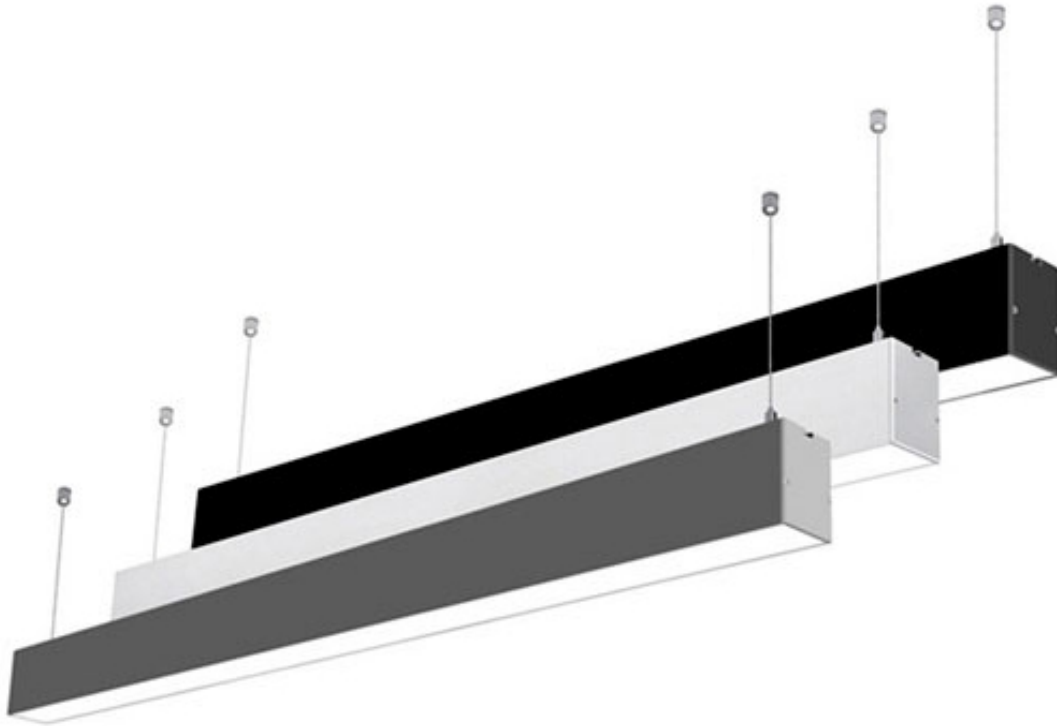

## Technical Specifications

### General

Driver : Constant Current  
 Input Voltage : 220-240Vac  
 Operating Temperature : +25°C ~ +55°C

### Light Source

Light Source : Edison 2835  
 CRI (Ra) : >80  
 LED Colour Temperature : 3000K / 4000K / 6500K  
 LED Lifetime : >50000hrs  
 Efficacy : 120lm/W

### Optical

Tilt : Fixed  
 Beam Angle : 100°  
 Diffuser Material : Polystyrene 70%  
 Diffuser Finish : Opal

### Physical

Body : High-Grade Extruded Aluminum  
 Mounting : Suspended (1mtr standard)  
 Finish : White(RAL9016)  
 Black(RAL9005)  
 Grey (RAL9006)

### Driver

Power Supply : Non Integral  
 Power Factor : >0.90  
 THD : <10%  
 Surge Protection : 2KV-3KV  
 Efficiency

## Pendant - Direct

ID	Direct	Dimension (mm)	System Lumens
5070 - 4ft	36W	1187 x 50 x 70	4320lm
5070 - 8ft	75W	2374 x 50 x 70	8750lm